

Features:

- A safe, quick and simple way to clamp Dies, Workpieces and Fixtures
- Easily inserted into existing T-Slots. Easily positioned without any set-up
- Manually operated. No hydraulic or pneumatic components necessary
- Clamping force is obtained through the patented OPTIMA Toggle System. Full pressure is achieved quickly and easily by turning the low torque "activation nut" 180°
- Self-locking in clamped position

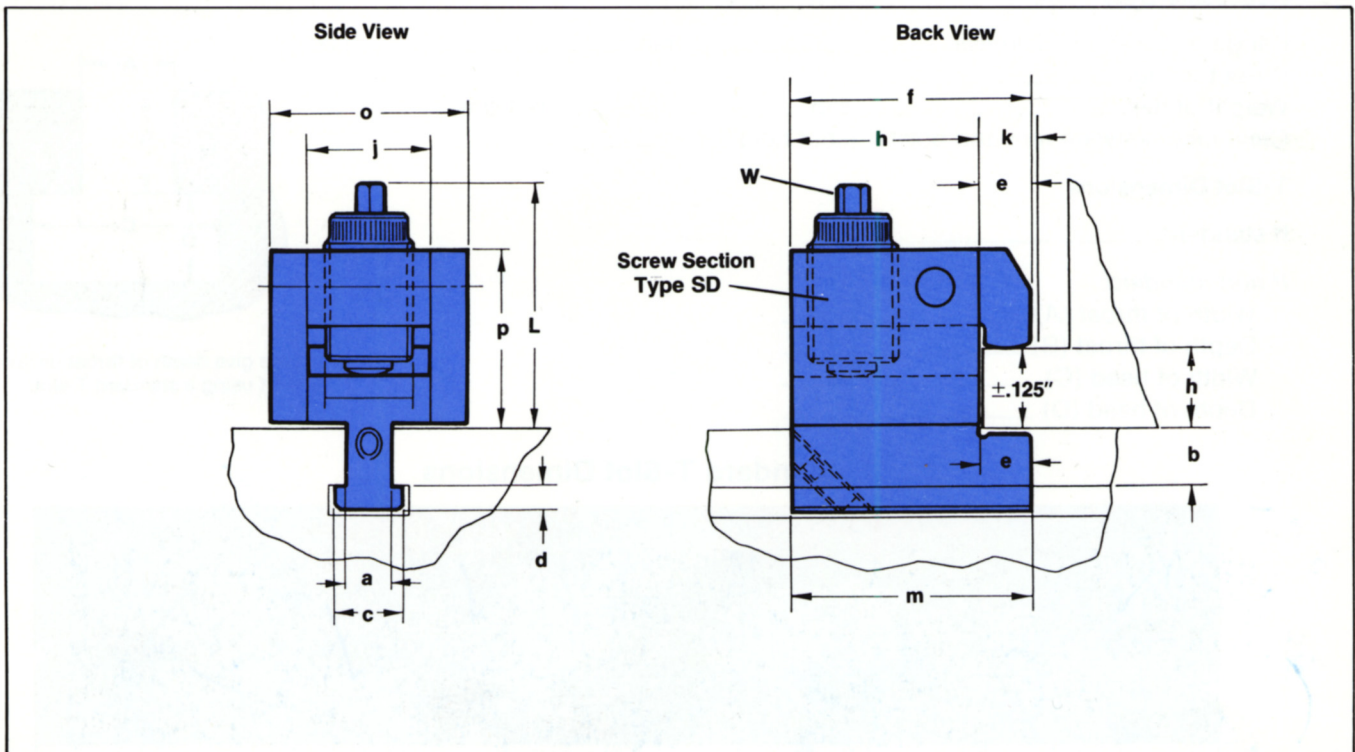
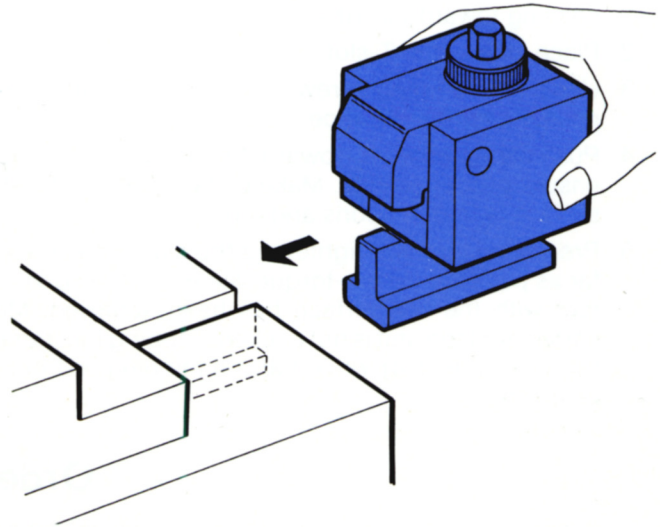

Type	Screw Section	Clamp Force - Tons	D	a	b	c	d	e	f	h+	j	k	L	m	n	o	p	Activation Nut W
MWE25	SD-36	3	M36 x 3					.79	3.78	.95-1.50	1.97	1.02	3.82	3.79	3.00	3.54	2.80	10 mm
MWE40	SD-48	5	M48 x 3	•	•	•	•	.98	4.80	1.18-1.81	2.36	1.26	4.92	4.80	3.82	4.33	3.43	17 mm, 11/16"
MWE63	SD-A64	7	M64 x 4					1.26	6.07	1.42-2.13	3.15	1.57	6.30	6.06	4.80	5.51	4.37	17 mm, 11/16"

Technical Data

Operating Procedure (SD):

To Clamp

1. Visually inspect clamp for obvious defects and make sure that the arrow on top of the "activation-nut" is pointing toward the **RED** dot.
2. Place clamp into T-slot.
3. Unscrew clamping screw sufficiently so that clamp jaw easily passes over the die shoe.
4. Push clamp forward (toward die) as far as possible to ensure proper seating. Make certain that the die shoe surface is free of debris and lubricants.
5. Pre-clamp by hand tightening the clamping screw as far as possible (to pre-torque value) so that solid contact with the die surface has been achieved. Make certain that the unit is not cocked. Tapping the frame of the unit (with fist) while hand-tightening will ensure proper fit.

Note: Maximum clamping force can be achieved by pre-clamping with a spanner wrench rather than hand-tightening.

6. With the use of a hex head wrench turn the "activation nut" 180° until it reaches its stop and the arrow is pointing toward the **GREEN** dot.

To Unclamp — Reverse procedure.

Operating Procedure (SD-A):

To Clamp

Due to an internal clutch mechanism preclamping and clamping are both activated by the activation nut. The activation nut is turned with a socket or open end wrench until the indicator line is pointing toward the green dot.

To Unclamp — Reverse procedure.

Ordering Information

When ordering or requesting a quote, please take a few minutes to complete the following data sheet.

Necessary Data

Range of die shoe thickness: (min. and max. values must be within .25" of each other) _____ min. _____ max.

Press tonnage: _____

Weight of dies: _____ top _____ bottom

Clearance between ram and bolster (shut height): _____

T-Slot Dimensions

If standard: _____

If non-standard:

Width of throat (A) _____

Depth of throat (B) _____

Width of head (C) _____

Depth of head (D) _____

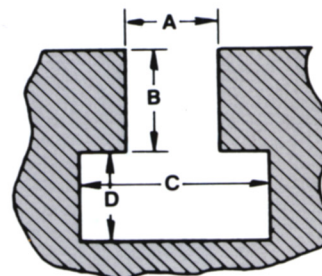

Note: Please give depth of throat dimension "B" even if using a standard T-slot.

Standard T-Slot Dimensions

Diameter of T-Bolt	Width of Throat A	Depth of Throat B		Head Space Dimensions and Tolerances					
				Width C			Depth D		
		Maximum	Minimum	Maximum (Basic)	Tolerance (Minus)	Minimum	Maximum (Basic)	Tolerance (Minus)	Minimum
1/4	9/32	3/8	1/8	9/16	0.063	1/2	15/64	0.031	13/64
5/16	11/32	7/16	5/32	21/32	0.063	19/32	17/64	0.031	15/64
3/8	7/16	9/16	7/32	25/32	0.063	23/32	21/64	0.031	19/64
1/2	9/16	11/16	5/16	31/32	0.063	29/32	25/64	0.031	23/64
5/8	11/16	7/8	7/16	1 1/4	0.063	13/16	31/64	0.031	29/64
3/4	13/16	1 1/16	9/16	1 15/32	0.094	13/8	5/8	0.031	19/32
1	1 1/16	1 1/4	3/4	1 27/32	0.094	13/4	53/64	0.047	25/32
1 1/4	1 5/16	1 9/16	1	2 7/32	0.094	2 1/8	1 3/32	0.063	1 1/32
1 1/2	1 9/16	1 15/16	1 1/4	2 21/32	0.094	2 9/16	1 11/32	0.063	1 9/32